

Responses to light under varying magnetic conditions in the honeybee, *Apis mellifica*

Thomas Leucht

Zoologisches Institut II der Universität Würzburg, Röntgenring 10, D-8700 Würzburg, Federal Republic of Germany

Accepted April 11, 1984

Summary. In the dance of honeybees the indication of direction to a food source can be influenced by magnetic and photic stimuli. We have tested the behaviour of dancing honeybees illuminated with white light under varying magnetic conditions. The bees respond to the light stimulus with a maximum deviation from the correct dancing direction when they dance parallel to the inclination of the earth's magnetic field (EMF). The response to light drops to zero with increasing deviation from this 'zero-point' direction (see also Martin and Lindauer 1977). The time of total indifference to light varies with the magnetic conditions. In the natural EMF the reaction to light becomes zero 20.3° (i.e. 1 h) after the bees have passed the zero-point. In the compensated EMF this effect is delayed by 10° . The bees show nearly no reaction to light when the EMF is amplified to 2 Gauss.

The relative spectral sensitivity of dancing honeybees was tested in the compensated EMF. It is 1:1.63:2.64 for green-, blue-, and UV-light, respectively.

Introduction

Honeybees indicate the direction toward a food-source by transposing the angle between the goal and the sun with respect to gravity when dancing on a vertical comb inside the dark hive. The direction toward the sun is indicated by dances in an upward direction. According to the movement of the sun, the dance angle changes with time of day (von Frisch 1965). The dance angle is strongly affected by the earth's magnetic field (EMF) and its daily variations. As a result, regular deviations from the correct dancing direction, the misdirection, can be observed (Lindauer and Martin 1968).

Abbreviation: EMF earth's magnetic field

Yet, there are a few discrete points (zero-points) where the EMF does not influence the correct waggle angle (Martin and Lindauer 1977). Provided a north-south alignment of the comb, this happens, when the waggle direction corresponds with the inclination of the EMF. At an inclinational angle of 65° (for Würzburg, Germany) zero-points can be observed at 25° and 205° , when assuming 0° for the upward dancing direction and observing the dances on the eastern side of the honeycomb. Figure 1 illustrates the spatial arrangement of the comb with respect to the magnetic field and the position of the zero-points. – If the EMF is compensated, the dances subsequently exhibit no misdirection over the whole dancing circle. – Another behavioural component of the dance, the sounds

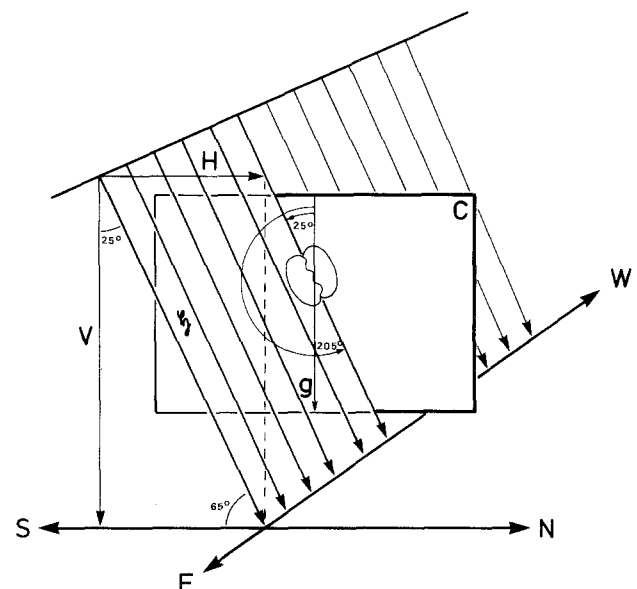

Fig. 1. Spatial arrangement of the comb relative to the EMF. N north; W west; S south; E east; V vertical component of the EMF; H horizontal component of the EMF; \vec{E} total intensity of the EMF; g gravity; C comb. (Martin, unpublished)

produced by forager bees, is also strongly correlated with the daily variations of the EMF (Kilbert 1979).

Wagging bees illuminated with light react with a pronounced divergence from the correct dance angle in the zero-points. The reaction to light declines with increasing deviation from the zero-point (Martin and Lindauer 1977). To quantify the effects induced by the interaction of photic and magnetic stimuli, we have tested the behaviour of dancing bees under 'white' light illumination with respect to the length of the photosensitive period after the zero-point had been reached under varying magnetic conditions.

A second aspect of this paper is concerned with the spectral sensitivity of dancing bees in the zero-point region under compensated EMF conditions. Here the absence of magnetically induced misdirection allows a direct measurement of light sensitivity.

Material and methods

General. The experiments were performed with honeybees belonging to the race *Apis mellifica carnica*. The bees were housed in an observation hive containing two combs and having UV-transmitting quartz-glass as broadsides. For measurement of the dance angles, a protractor was attached to the glass window, allowing an accuracy of measurement up to 1°. Dance angles were determined by assuming 0° for the vertically upward direction and counting off through 360°. The bees danced on the east side of the vertical comb in the zero-point region of 25° and 205° (i.e. 15°–100° and 190°–245°, respectively). The hive was adjusted in north-south direction. A group of 20–25 individually marked foragers were trained to visit an artificial food source containing sugar water 700 m remote from the hive. An assistant caught away newcomers to prevent overcrowding of the feeding place. – All experiments were performed near Würzburg, Germany.

Variation of the EMF. Variation of the magnetic field was obtained by means of Helmholtz coils which were adjusted in the direction of the EMF's inclination. The current in the coils could be altered with an adjustable resistance. The experiments were conducted under three different magnetic conditions: EMF normal (total intensity about 0.5 Gauss), EMF amplified to 2 Gauss, and EMF compensated to less than 4% of total intensity. The magnetic stimuli were switched on 1 h before the start of measurements. The quality of the stimuli was repeatedly controlled during each experiment with a Gaussmeter (Bell 640) by placing the probe directly in the position of the dancing honeybee.

Light stimuli. The bees were illuminated with the light from a 100 W tungsten lamp with UV-transmitting quartz condenser, heat filter KG1 (Schott), neutral grey and interference filters (Spindler & Hoyer). The distance between lamp and dancing floor was 40 cm. The stimulus subtended an angle of 5° at the bee's eye. The bees were lit from beneath under an elevational angle of 45° with respect to the vertical comb and an azimuthal angle of 180°. In the experiments varying the magnetic field conditions, 'white' light with an intensity of $0.26 \times 10^2 \mu\text{W}/\text{cm}^2$ was used. – In the spectral sensitivity measurements, three interference filters were used with λ_{max} at 348 nm, 440 nm, and 548 nm. In the zero-point region at 25°,

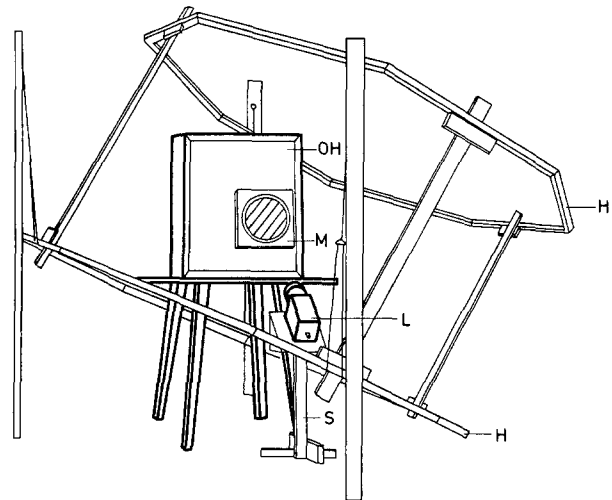

Fig. 2. Principle of experimental set up. OH observation hive; L lamp; M measuring wheel; H Helmholtz coil; S support

the irradiance values were tuned to equal energies as follows: 348 nm: 0.100×10^2 ; 440 nm: 0.125×10^2 ; 548 nm: $0.125 \times 10^2 \mu\text{W}/\text{cm}^2$. In the zero-point region at 205°, quantum densities were equalized: 348 nm: 0.110×10^2 ; 440 nm: 0.790×10^1 ; 548 nm: $0.640 \times 10^1 \mu\text{W}/\text{cm}^2$. Measurements of light intensities were conducted with an optometer (UDT 40 ×; United Detector Technology) in the laboratory simulating outdoor conditions. All spectral sensitivity experiments were performed under compensated EMF conditions. The whole experimental setup (Fig. 2) was placed inside a tent to achieve darkening of less than 4 Lux. Under these conditions dancing honeybees show no phototactically induced misdirection (Martin and Lindauer 1977).

Experimental procedure. Feeding of the marked foragers as well as compensation or amplification of the EMF started 1 h before the beginning of dance measurements. The measurement period started 15–20 min, i.e. 10°, before the zero-point and lasted at least 3 h. During this period 15 min of light stimulus alternated with a 15 min control-phase of diffuse illumination below 4 Lux. Before measuring the dance angle every bee had to perform at least 10 dances as 'tuning-in' phase. Only then the measurement was made.

Results

The present experimental results indicate that the sensitivity of dancing honeybees to light is directly influenced by magnetosensory inputs, or vice versa. Generally, a maximum light-induced misdirection is observed in the zero-point region at 205°, where the dancing direction corresponds with the inclination of the EMF when measuring the dances on the eastern side of the honeycomb. – A comparison of the curves obtained under the specified magnetic conditions reveals differences in absolute reactivity in the zero-point region as well as in the length of the phase, where dance errors can be induced by light. Figures 3 and 4 show examples. In the figures circles and triangles represent the mean values of those measurements that were ob-

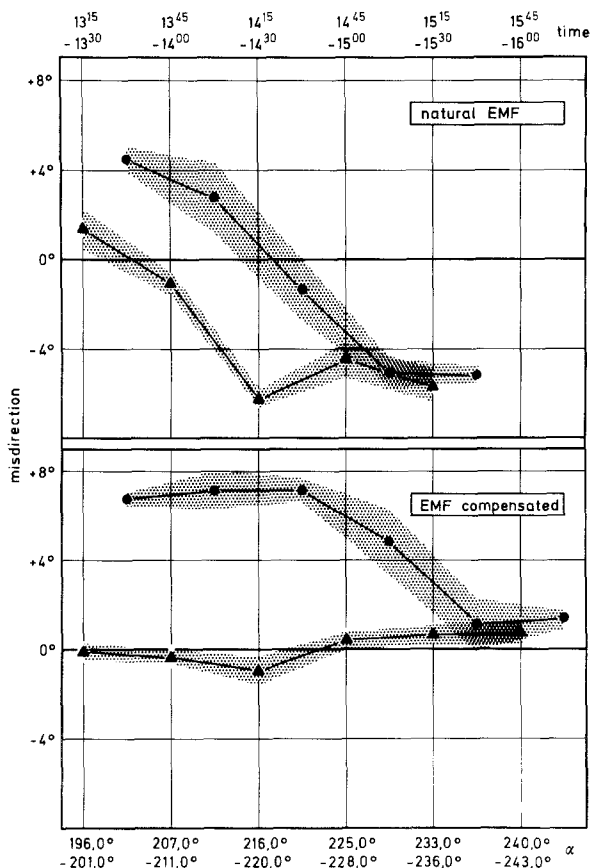

Fig. 3. Responses of dancing honeybees to light under normal and compensated EMF-conditions. ●—● misdirection with light; ▲—▲ misdirection without light stimulus. The symbols represent the mean of dances obtained in a 15-min period. Dotted areas: standard deviation. α , angle between food source and the sun. Experiment performed on August 30, 1982 (natural EMF) and on August 29, 1982 (EMF compensated)

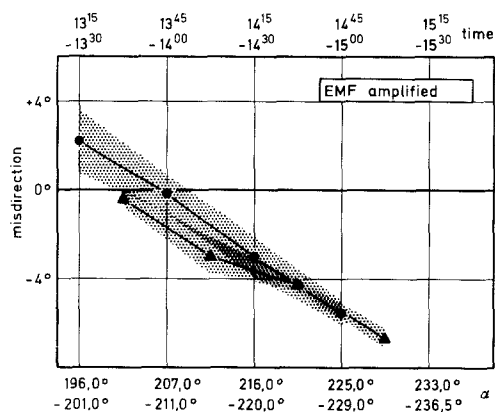

Fig. 4. Responses of dancing honeybees to light under amplified EMF conditions. Experiment performed on September 3, 1982

tained during 15 min-periods with light stimulus (circles) and control periods (triangles) in dim light below 4 Lux. In the normal, uncompensated EMF the reaction to light vanishes at a dance angle of 225.3°, i.e. 20.30° (SD: 1.04) or 57.6 min (SD: 7.7)

after the zero-point. In the compensated EMF bees do not exhibit any more light-induced misdirection at a dance angle of 235.17°, i.e. 30.17° (SD: 2.38) or 100.7 min (SD: 9.4). The indicated periods are determined graphically by interpreting the point of intersection of two corresponding curves with light stimulus and without light stimulus at the time where no more light-induced errors occur. Amplification of the EMF by a factor of 4, i.e. 2 Gauss, produced no reaction at all as for absolute reactivity in the zero-points and the length of the period where light-induced misdirections can be observed.

The influence of spectral light stimuli on the direction indication of dancing honeybees has been determined for the wavelengths with maximum absorption in the three photoreceptor pigments in the bee's eye. Measurements were taken in the zero-point region of 25° and 205° under compensated EMF-conditions. Figures 5, 6, and 7 illustrate examples from curves obtained in the zero-point region at 25° where the bees were illuminated with equal intensities of light. The reactions of bees in the zero-point region of 205° are shown in Figs. 8, 9, and 10. Here the different spectral stimuli were tuned to nearly equal quantal content. Each figure represents the combination of two single misdirection curves whose stimulus- and control-phases had been shifted by 15 min, thus obtaining one complete misdirection curve for light stimulus and controls in dim light, respectively.

In the 25°-region the bees generally respond with a negative misdirection, in the 205°-region the sign of the phototactically induced error in the dancing direction is always positive. In both cases the bees react to the light stimulus by enlarging the angle between the light source and the waggle direction, thus expressing a negative phototactic behaviour.

The present experimental results show that ultraviolet light has the largest effectiveness referring to the light-induced error in direction-indication.

Table 1. Mean light-induced misdirections in the zero-point range from 25°–45° (stimulated with equal intensity per wavelength) and in the zero-point range from 205°–225° (stimulated with equal numbers of quanta). \bar{x} mean misdirection; SD standard deviation. – Data are based on 24 experiments

Zero-point	λ_{max}	\bar{x}	SD	n
25°	548 nm	10.10°	1.17	91
	440 nm	10.44°	1.50	86
	348 nm	13.53°	1.47	85
205°	548 nm	4.92°	0.65	31
	440 nm	5.89°	0.89	33
	348 nm	11.84°	1.68	31

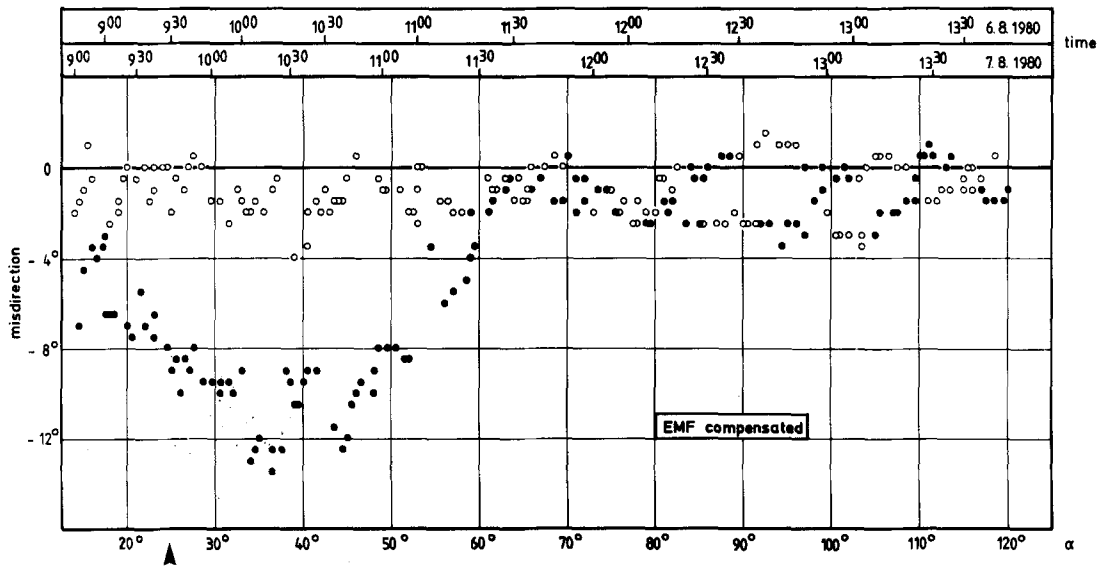

Fig. 5. Misdirection of honeybees illuminated with green light (filled symbols). Open symbols: controls without light stimulus. Each symbol represents measurements from one dancing bee. α , angle between foodsource and the sun; \blacktriangleright zero-point (25°)

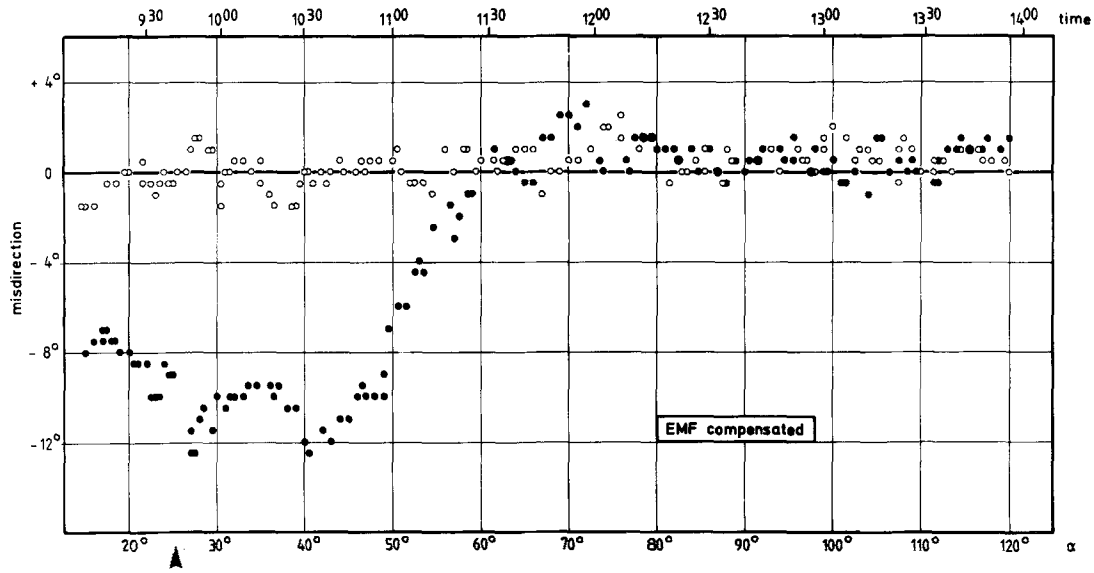

Fig. 6. Misdirection of honeybees illuminated with blue light (filled symbols). Open symbols: controls without light stimulus. Experiments performed on August 9 and 10, 1980

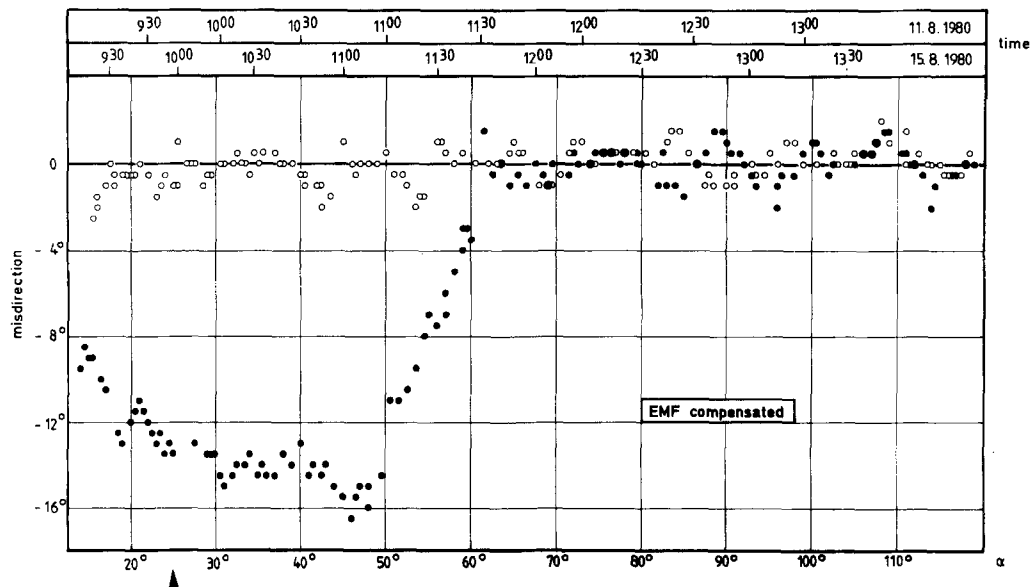

Fig. 7. Misdirection of honeybees illuminated with UV-light (filled symbols). Open symbols: controls without light stimulus

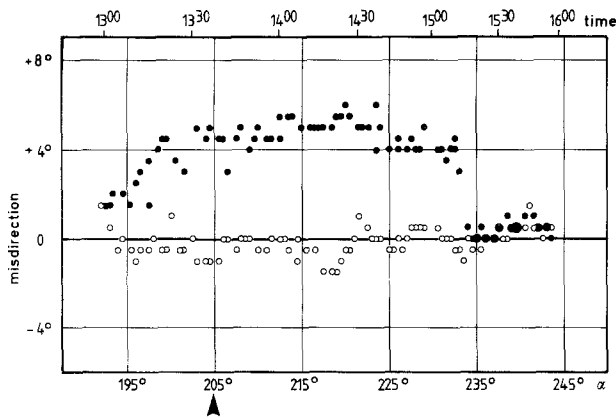

Fig. 8. Misdirection of honeybees illuminated with green light (filled symbols). Open symbols: controls without light stimulus. Each symbol represents measurements from one dancing bee. α , angle between foodsource and the sun; \blacktriangleright zero-point (205°). Experiments performed on September 2 and September 3, 1981

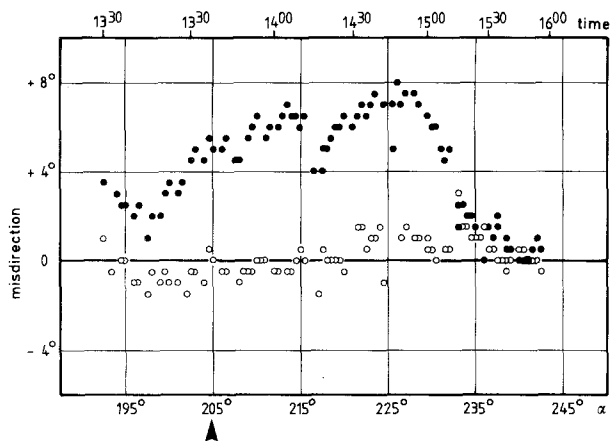

Fig. 9. Misdirection of honeybees illuminated with blue light (filled symbols). Open symbols: controls without light stimulus. Experiments performed on September 7 and 8, 1981

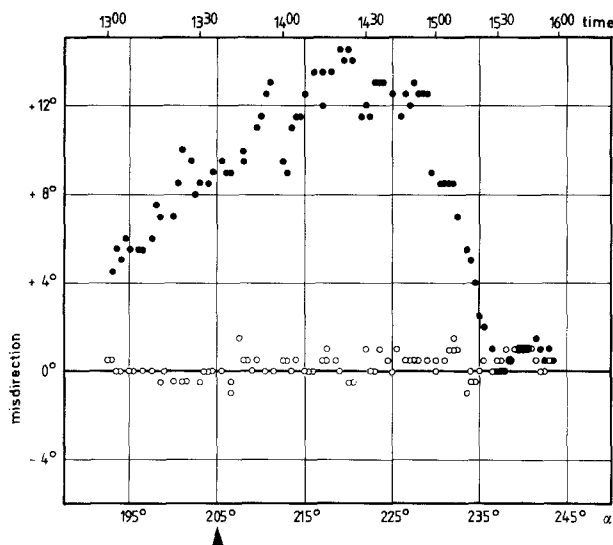

Fig. 10. Misdirection of honeybees illuminated with UV-light (filled symbols). Open symbols: controls without light stimulus. Experiments performed on September 4 and 5, 1981

Blue and green stimuli show much lower effects. The light-induced misdirections under the different spectral stimuli are listed in Table 1. After approximating the results for equal quanta the following ratio of stimulus effectiveness was obtained: $548 \text{ nm}:440 \text{ nm}:348 \text{ nm}=1:1.63:2.64$ in the region from 25° – 45° and $1:1.22:2.63$ in the region from 205° – 225° , respectively.

Discussion

The observations described above give a first quantitative idea about the influence of magnetic fields on reactions to light in dancing honeybees. The experimental results demonstrate a correlation between the intensity of the applied magnetic stimuli and the length of the light-effective period. Thus, not only gravity perception is affected by magnetic fields (Lindauer and Martin 1968) but also the behavioural reactions to light. Magnetic stimuli therefore seem to have at least a bimodal influence on the sensory and/or central level.

The fact that also in the compensated EMF the reactivity to light drops to zero was somewhat irritating. We had expected that compensation is followed by a constant light-induced misdirection over the whole dancing circle. Yet, it has to be borne in mind that only the constant EMF, i.e. the mean total intensity as well as the corresponding mean direction of this vector, can be cancelled by Helmholtz coils but not the variations of intensity. Though these variations make up less than 2% of the total intensity of the EMF (Dubrov 1978), this value seems to be sufficient to reduce the reaction to light to zero, though delayed in time when compared with the results obtained under normal EMF conditions. Besides the results of Lindauer and Martin (1968) in bees and Keeton et al. (1974) in pigeons this can be interpreted as another indication for the ability of animals to perceive variations of the EMF in the γ -range.

The results obtained in the compensated EMF do not only hold for the 205° -region. A comparison with the data in the 25° -region (see Figs. 4 to 6) shows that the reactivity to light drops to zero too. In the first case the angle between the light source and the direction indication is 25° , in the second case it is 155° . Thus, the angle between light source and the dancing bee as well as the dancing direction relative to gravity seems to have no influence on the observed effects.

A comparison of the results obtained under different magnetic conditions indicates that constant and variable components of the EMF interact synergistically insofar as the ratio between the mean total intensity and the intensity of variation of the EMF determines the length of the light-effective

period. In this context the pronounced time lag in the loss of reactivity to light may be interpreted as follows: The measurement of the direction of inclination under low magnetic field intensities is only possible after longer exposition than under normal or even amplified EMF conditions. Such a mechanism postulates a time dependent averaging modus of intensity processing.

The misdirection by light-effect depends on the spectral composition of the stimuli. The ratio of reactivity with respect to the tested colours is shown in Table 1. We have tested in the zero-point region from 25°–45°. Control experiments in the region from 205°–225° revealed similar results. For the following discussion we refer to the results in the region from 25°–45° only.

A determination of the spectral sensitivity of honeybees by means of their direction indication has been carried out by Edrich (1979). The experiments demonstrate that only the blue and green receptors of the bee's eye are involved in the reaction, thus indicating that blue and green light is interpreted as sunlight. The different results presented here may be explained in terms of differences in the experimental setup, i.e. size and position of the light source, inclination of the dancing surface, and magnetic field situation. Especially the spatial relation between lamp and dancing platform in our experiments make it unlikely that the bees interpret the light as sunlight.

Comparison with data from other previous findings shows qualitative agreement; yet, there are partly considerable quantitative differences: Daumer (1956) found an UV/green ratio of 5.6:1, von Helversen (1972) found a ratio of 16:1. It has to be considered, however, that the authors worked with a rewarding technique, thus producing a colour specific conditioning of the bees influencing the assessment of the colours. One example may be the importance of UV-reflecting nectaries for foraging bees. – In addition, the stimulated eye-region in the cited experiments is the ventral one, whereas we have illuminated the dorsal part of the eye. It seems likely that differences like this have behavioural consequences since regional specializations in the bee's eye have been shown by several authors (Kaiser and Liske 1974; Labhart 1980; Moore et al. 1981).

Acknowledgements. I wish to thank Prof. Dr. H. Martin for continuous interest and support during the course of this work and Prof. Dr. M. Lindauer giving the possibility to work in his institute. This work was partially financed by the Akademie der Wissenschaften und der Literatur, Mainz.

References

- Daumer J (1956) Reizmetrische Untersuchung des Farbensehens der Bienen. *Z Vergl Physiol* 38:413–478
- Dubrov AP (1978) The geomagnetic field and life. Plenum Press, New York London
- Edrich W (1979) Honey bees: Photoreceptors participating in orientation behaviour to light and gravity. *J Comp Physiol* 133:111–116
- Frisch K von (1965) *Tanzsprache und Orientierung der Bienen*. Springer, Berlin Heidelberg New York
- Helversen O von (1972) Zur spektralen Unterschiedsempfindlichkeit der Honigbiene. *J Comp Physiol* 80:439–471
- Kaiser W, Liske E (1974) Die optomotorischen Reaktionen von fixiert fliegenden Bienen bei Reizung mit Spektrallichtern. *J Comp Physiol* 89:95–103
- Kaiser W, Seidl R, Vollmar J (1977) The participation of all three colour receptors in the phototactic behaviour of fixed walking honeybees. *J Comp Physiol* 122:27–44
- Keeton WT, Larkin TS, Windsor DM (1974) Normal fluctuations in the Earth's magnetic field influence pigeon navigation. *J Comp Physiol* 95:95–103
- Kilbert K (1979) Geräuschanalyse der Tanzlaute der Honigbiene (*Apis mellifica*) in unterschiedlichen magnetischen Feldsituationen. *J Comp Physiol* 132:11–25
- Labhart T (1974) Behavioural analysis of light intensity discrimination and spectral sensitivity in the honey bee. *J Comp Physiol* 95:203–216
- Labhart T (1980) Specialized photoreceptors at the dorsal rim of the honeybee's compound eye. *J Comp Physiol* 141:19–30
- Laughlin SB (1976) The sensitivities of dragonfly photoreceptors and the voltage gain of transduction. *J Comp Physiol* 111:221–247
- Lindauer M, Martin H (1968) Die Schwereorientierung der Bienen unter dem Einfluß des Erdmagnetfeldes. *Z Vergl Physiol* 60:210–243
- Martin H, Lindauer M (1977) Der Einfluß des Erdmagnetfeldes auf die Schwereorientierung der Honigbiene. *J Comp Physiol* 122:145–187
- McFarland WN, Munz FW (1976) The visible spectrum during twilight and its implication to vision. In: Evans GC, Bainbridge R, Rackham O (eds) *Light as an ecological factor*. Blackwell Sci Publ, Oxford Edinburgh London Melbourne Vol II, pp 249–270
- Menzel R (1979) Spectral sensitivity and colour vision in invertebrates. In: Autrum H (ed) *Vision in invertebrates*. Springer, Berlin Heidelberg New York (Handbook of sensory physiology, vol 7/6A, pp 503–580)
- Moore D, Penikas J, Rankin M (1981) Regional specialization for an optomotor response in the honeybee compound eye. *Physiol Entomol* 6:61–69